



more durable, efficient, beautiful

4184 E. Conant St.
Long Beach, CA 90808
Tel. 310-900-1000
Fax. 310-900-1077
www.turboairinc.com

| | |
|-------------------|--------|
| Project: | |
| Model #: | |
| Item #: | |
| Available W/H: | Qty: |
| Approval: | |
| AIA #: | SIS #: |
| CSI Section 11400 | |

Glass / Mug Frosters

Underbar Equipment
Super Deluxe Series

Patented Self-Cleaning Condenser

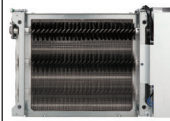

This product is equipped with a fine mesh filter to the front of the condenser to catch dust, and a rotating brush that moves up and down daily to remove excess buildup outward and away.

Model : TBC-36SD-GF-N
TBC-36SB-GF-N



TBC-36SD-GF-N



TBC-36SB-GF-N

≡ FEATURES & BENEFITS ≡

- **Self-Cleaning Condenser**
The accumulation of dust in the condenser can cause the failure or breakdown of refrigerators. Refrigerators run normally until they reach a certain level of accumulation. At some point, when they are over the limit, their performance drops quickly resulting in damage to, or disposal of the stored products inside. The Self-Cleaning Condenser device keeps the condenser clean and prevents system failure by automatically brushing daily.
- **Hydrocarbon refrigerants (R-290)**
With innovative and eco-friendly technology, Turbo Air brings you hydrocarbon refrigerators designed to meet DOE's Energy Conservation Standards in 2017 and to use EPA's SNAP Program approved HC refrigerants. Hydrocarbon refrigerants do not deplete the ozone layer and have very low contribution to global warming (ODP-0, GWP-3).
- **Stainless steel cabinet construction**
Super Deluxe (SD) models boast a stainless steel exterior (except galvanized steel back and bottom). SB models have an attractive wear-resistant black vinyl exterior. Heavy gauge stainless steel countertop and glide lids are perfect for sanitation and durability. The interior is stainless steel except galvanized steel top. Turbo Air Glass Froster model guarantees the utmost in cleanliness and long product life. It also adds a touch of style to the most refined setting.
- **Manual defrost system**
- **High-density polyurethane insulation**
The entire cabinet structure is foamed-in-place using high density, HCFC free polyurethane insulation.
- **Heavy duty, PE (polyethylene) coated dividers**
Heavy duty 10mm thick pure grade PE coated shelves are provided for maximum storage use.
- **Direct cooling type**
- **Large capacity cooler cabinet requires only minimum floor space**
- **Side mount compressor unit**
With compressors positioned on the side of the unit, our refrigerators can now be serviced without being moved. Our innovative, front air intake feature also allows this model to be highly efficient in narrow spaces.
- **Glass/mug froster holds -5°F ~ 15°F for the best in chilling glasses and plates**



| Model | Sliding Doors | CU./FT. | Capacity 8" Mug / 10oz Stein | # of Shelves | HP | AMPS | Crated Weight (lbs.) | L x D x H† (inches) |
|---------------|---------------|---------|---------------------------------|--------------|-----|------|----------------------|--------------------------|
| TBC-36SD-GF-N | 1 | 9.74 | 93 / 227 Cups | 5 | 1/3 | 1.6 | 201 | 36 3/4 x 26 1/2 x 33 1/4 |
| TBC-36SB-GF-N | 1 | 9.74 | 93 / 227 Cups | 5 | 1/3 | 1.6 | 201 | 36 3/4 x 26 1/2 x 33 1/4 |

Model : TBC-36SD/SB-GF-N

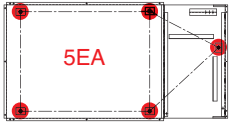
| ELECTRICAL DATA | |
|--------------------------------|--|
| Voltage | 115/60/1 |
| Plug Type |  NEMA 5-15P |
| Full Load Amperes | 1.6 |
| Compressor HP | 1/3 |
| Refrigerant | R-290 |
| Cord Length (ft.) | 8.5 |
| DIMENSIONAL DATA | |
| Capacity (8" Mug / 10oz Stein) | 93 Cups / 227 Cups |
| Net Capacity (cu. ft.) | 9.74 |
| Ext. Length Overall (in.) | 36 ³ / ₄ (934mm) |
| Ext. Depth Overall (in.)* | 26 ¹ / ₂ (673mm) |
| Ext. Height Overall (in.)† | 33 ¹ / ₄ (844mm) |
| # of Shelves | 5 |
| # of Casters |  5EA |
| Net Weight (lbs.) | 190 |
| Gross Weight (lbs.) | 201 |

Design and specifications subject to change without notice.

Actual shipping weight may differ due to extra packing materials for product protection.

* Depth does not include 1-1/4" for rear spacers.

† Height does not include 3-1/8" for caster height.

- **WARRANTY : 5 Year Parts and Labor Warranty
7 Year Compressor Warranty**

■ STANDARD FEATURES

- *Anti-corrosion coated evaporator*
- *Self-contained system*
- *2.5" dia. swivel casters with locks on the front set*
- *Door locks*

■ OPTIONAL ACCESSORIES

- 1" caster, 1/2" diameter & 13 TPI: S28R813660 (non-brake)
- 2" caster for underbar series, 1/2" diameter: P0165B0100 (non-brake), P0165B0110 (w/ brake)
- 4" caster, 1/2" diameter & 13 TPI: 30265L0400 (non-brake), 30265L0300 (w/ brake)
- 5" caster, 1/2" diameter & 13 TPI: M726500100 (non-brake), M726500200 (w/ brake)
- Leveling leg, 1/2" - 13 TPI x 1.54": LFM1213566
- 6" adjustable stainless steel leg: P0121P0100

PLAN VIEW

(unit : inch)

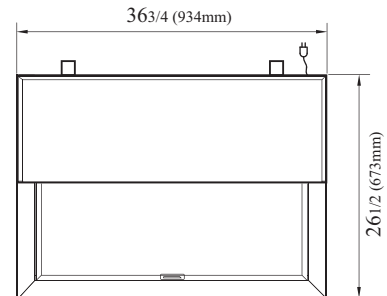

TOP VIEW

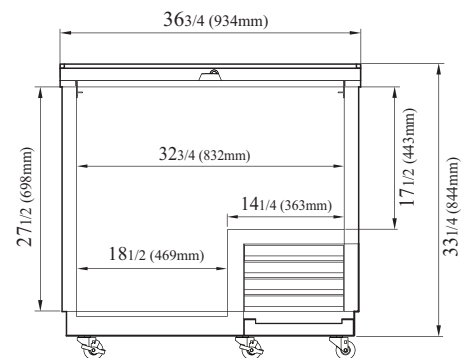

FRONT VIEW

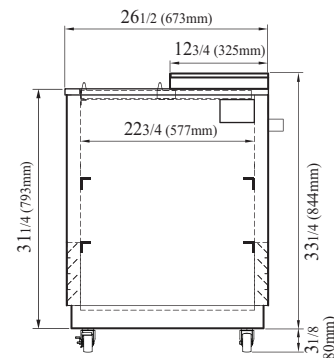

SIDE VIEW

Ver.20241118



- Turbo Air: 800-627-0032
- Radiance: 800-500-3519
- Warranty: 800-381-7770
- AC: 888-900-1002