

**REFRIGERATOR MANUFACTURER**  
**Turbo air**  
 more durable, efficient, beautiful

4184 E. Conant St.  
 Long Beach, CA 90808  
 Tel. 310-900-1000  
 Fax. 310-900-1077  
[www.turboairinc.com](http://www.turboairinc.com)

Project:	
Model #:	
Item #:	
Available W/H:	Qty:
Approval:	
AIA #:	SIS #:
CSI Section 11400	

## Curved Glass Bakery Cases

Display Cases  
 Bakery Cases - Combination Cases

### Patented Self-Cleaning Condenser



This product is equipped with a fine mesh filter to the front of the condenser to catch dust, and a rotating brush that moves up and down daily to remove excess buildup outward and away.

**Model : TCGB-60-CO-R**  
**REFRIGERATED & DRY CASE**  
**COMBINATION**



### ≡ FEATURES & BENEFITS ≡

- **Self-Cleaning Condenser**  
 The accumulation of dust in the condenser causes the failure or breakdown of refrigerators. Refrigerators run normally until they reach a certain level of accumulation. At some point, when they are over the limit, their performance drops quickly resulting in damage to, or disposal of the stored products in refrigerators. The self-cleaning condenser device keeps the condenser clean and prevents system failure by automatically brushing daily.
- **Attractive, elegant, glass sided Euro design**  
 Curved tempered front glass and minimal frame provide full product visibility to optimize display effects. Its elegant contemporary euro design and luxurious wine colored case will not only enhance any store atmosphere but also will keep product presentation at its best and beautiful.
- **High-density polyurethane insulation**  
 The entire cabinet structure is foamed-in-place using high density, CFC free polyurethane insulation.
- **Low-E coated double pane glass is tempered for safety**
- **Heavy duty, white PE coated wire shelves**
- **Cantilevered wired shelves adjustable up and down, tilted**
- **Stainless steel floor and airflow grille**
- **Sliding rear doors for product loading and unloading**
- **Rear access of compressor compartment for quick and easy service**
- **Refrigerated bakery case holds avg. 33°F ~ 41°F for fresher bakery products**



Model	CU./FT.	# of Shelves	HP	AMPS	Crated Weight (lbs.)	L x D x H (inches)
TCGB-60-CO-R	10.37 x 2	4	1/3	6.5	721	60 1/2 x 34 1/4 x 50 1/8

## Model : TCGB-60-CO-R

ELECTRICAL DATA	
Voltage	115/60/1
Plug Type	 NEMA 5-15P
Full Load Amperes	6.5
Compressor HP	1/3
Refrigerant	R-134A
DIMENSIONAL DATA	
Net Capacity (cu. ft.)	10.37 x 2
Ext. Length Overall (in.)	60 1/2 (1537mm)
Ext. Depth Overall (in.)	34 1/4 (870mm)
Ext. Height Overall (in.)	50 1/8 (1273mm)
Int. Length Overall (in.)	28 (711mm) x 2
Int. Depth Overall (in.)	27 3/4 (705mm)
Int. Height Overall (in.)	22 3/4 (578mm)
Net Weight (lbs.)	629
Gross Weight (lbs.)	721
# of Shelves	4

Design and specifications subject to change without notice.  
Actual shipping weight may differ due to extra packing materials for product protection.

- **WARRANTY : 2 Year Parts and Labor Warranty**  
Additional 3 Year Warranty on Compressor

### STANDARD FEATURES

- Anti-corrosion coated evaporator
- Self-contained system, no plumbing required
- Safety shielded LED lighting interior
- Solar powered digital thermometer
- Digital electronic thermostat with defrost control

#### Recommended operation conditions

TCDD models are designed to operate in an environment where temperature & humidity do not exceed 75°F and 55% respectively. Units should not be installed near HVAC vents, fans or doorways that will disrupt the air curtain and compromise the function of the cabinet. Air curtain models will run most efficiently when completely loaded with product.

## PLAN VIEW

(unit : inch)

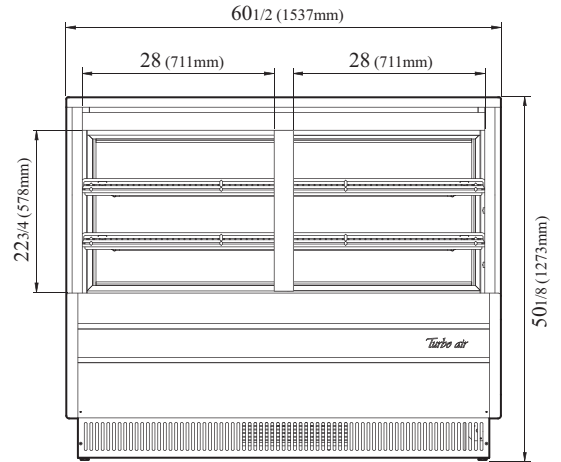

FRONT VIEW

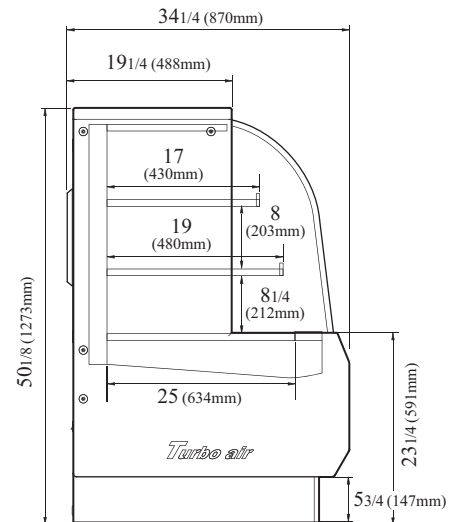

SIDE VIEW

Ver.20201223



- Turbo Air : 800-627-0032
- GK : 800-500-3519
- Warranty : 800-381-7770
- AC : 888-900-1002