



more durable, efficient, beautiful

4184 E. Conant St.  
Long Beach, CA 90808  
Tel. 310-900-1000  
Fax. 310-900-1077  
[www.turboairinc.com](http://www.turboairinc.com)

Project:	
Model #:	
Item #:	
Available W/H:	Qty:
Approval:	
AIA #:	SIS #:
CSI Section 11400	

## Solid Door Freezer

Reach-In Bottom Mount  
Super Deluxe Series

**Model : TSF-23SD-N  
TSF-23SD-N-L**

### FEATURES & BENEFITS

#### Self-Cleaning Condenser

The accumulation of dust in the condenser can cause the failure or breakdown of refrigerators. Refrigerators run normally until they reach a certain level of accumulation. At some point, when they are over the limit, their performance drops quickly resulting in damage to, or disposal of the stored products inside. The Self-Cleaning Condenser device keeps the condenser clean and prevents system failure by automatically brushing daily.

#### Digital temperature control & monitor system

- Keeps food products safe by maintaining constant temperatures
- Alarms that sound when doors are not sealed shut; protect against food spoilage that originates from cold air leaks
- Early warning alarm program detects issues before malfunction occurs
- Digital display allows for easy monitoring
- Programs interpret the condition of refrigeration systems by self-diagnosis
- Rapid cool-down function (Turbo Freeze)
- Smart defrost system will defrost as needed
- Automatic evaporator fan motor delays

#### Hydrocarbon refrigerants (R-290)

With innovative and eco-friendly technology, Turbo Air brings you hydrocarbon refrigerators designed to meet DOE's Energy Conservation Standards in 2017 and to use EPA's SNAP Program approved HC refrigerants. Hydrocarbon refrigerants do not deplete the ozone layer and have very low contribution to global warming (ODP-0, GWP-3).

#### Stainless steel cabinet construction

The Turbo Air Super Deluxe model boasts a stainless steel interior and exterior (galvanized steel top, bottom and back). It guarantees the utmost in cleanliness and long product life. Sharp corners and edges have been rounded to reduce the risk of injury. The Super Deluxe adds a touch of style to the most refined setting.

#### Sturdy, clean stainless steel shelving

Shelves are the most important part of cleanliness as they come in direct contact with food. After a while, PVC coated wire shelves may peel, rust and lead to unsanitary conditions. Only the Turbo Air Super Deluxe series uniquely provides stainless steel shelving.

#### Door pressure release device

Pressure relief doors are designed to eliminate vacuum pressure and allow easy door opening.

#### High-density polyurethane insulation

The entire cabinet structure and solid doors are foamed-in-place using high density, HCFC free polyurethane insulation.

#### LED interior lighting

#### Bottom mount compressor

- TSF-23SD-N: Right hinged
- TSF-23SD-N-L: Left hinged



Freezer holds -10°F ~ 0°F for the best in frozen food preservation

#### Patented Self-Cleaning Condenser

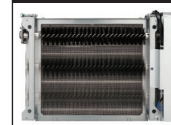

This product is equipped with a fine mesh filter to the front of the condenser to catch dust, and a rotating brush that moves up and down daily to remove excess buildup outward and away.

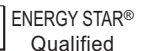

Model	Swing Door	CU./FT.	#of Shelves	HP	AMPS	Crated Weight (lbs.)	L x D x H* (inches)
TSF-23SD-N(-L)	1	19.03	3	1/2	4.8	293	27 x 30 <sup>3</sup> / <sub>8</sub> x 78 <sup>1</sup> / <sub>4</sub>

# Solid Door Freezer

Reach-In Bottom Mount  
Super Deluxe Series

## Model : TSF-23SD-N(-L)

ELECTRICAL DATA	
Voltage	115/60/1
Plug Type	 NEMA 5-15P
Full Load Amperes	4.8
Compressor HP	1/2
Cord Length (ft.)	7
Refrigerant	R-290
DIMENSIONAL DATA	
# of Doors	1
# of Racks Accepted	1
Net Capacity (cu. ft.)	19.03
Ext. Length Overall (in.)	27 (685mm)
Ext. Depth Overall (in.)	30 <sup>3</sup> / <sub>8</sub> (770mm)
Ext. Height Overall (in.)*	78 <sup>1</sup> / <sub>4</sub> (1987mm)
Int. Length Overall (in.)	23 (585mm)
Int. Depth Overall (in.)	26 <sup>1</sup> / <sub>8</sub> (665mm)
Int. Height Overall (in.)	52 <sup>1</sup> / <sub>4</sub> (1318mm)
# of Shelves	3
Shelf Size (L x D) (in.)	22 x 23 <sup>1</sup> / <sub>2</sub>
Net Weight (lbs.)	280
Gross Weight (lbs.)	293

Design and specifications subject to change without notice.  
Actual shipping weight may differ due to extra packing materials for product protection.  
\* Height does not include 5" caster height.

### ■ WARRANTY : 5 Year Parts and Labor Warranty 7 Year Compressor Warranty

### ■ STANDARD FEATURES

- Anti-corrosion coated evaporator
- Door locks
- Positive seal self-closing doors
- Easy replaceable one piece magnetic door gaskets
- Self-contained system
- Solid and sturdy grille design
- 4" dia. swivel casters with locks on the front set

### ■ OPTIONAL ACCESSORIES

- 5" caster, 1/2" diameter & 13 TPI: M726500100 (non-brake), M726500200 (w/ brake)
- 6" stainless steel leg: 30221M0600
- Additional stainless steel shelf: 30278Q0100
- Half door bun tray rack: TSP-2224 (each holds up to six 18"L x 26"D sheet pans)
- Full door bun tray rack: TSP-2250-T (each holds up to fifteen 18"L x 26"D sheet pans)

Ver.20240621

## PLAN VIEW

(unit : inch)

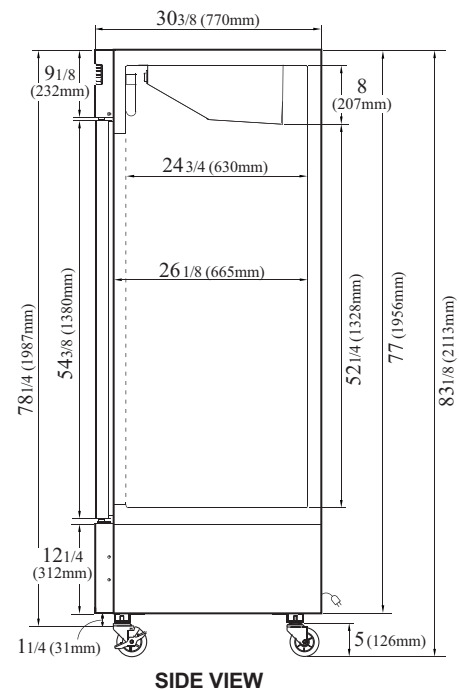
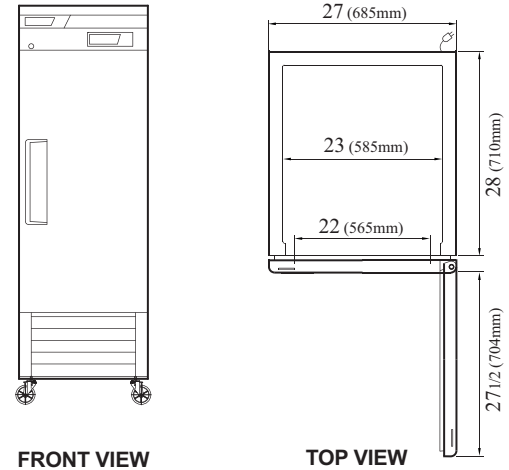

- Turbo Air: 800-627-0032
- Radiance: 800-500-3519
- Warranty: 800-381-7770
- AC: 888-900-1002