

TURBO AIR REFRIGERATOR MANUFACTURER
Turbo air

more durable, efficient, beautiful

4184 E. Conant St.
 Long Beach, CA 90808
 Tel. 310-900-1000
 Fax. 310-900-1077
www.turboairinc.com

| | |
|-------------------|--------|
| Project: | |
| Model #: | |
| Item #: | |
| Available W/H: | Qty: |
| Approval: | |
| AIA #: | SIS #: |
| CSI Section 11400 | |

Undercounter Freezer - Drawers

*Undercounters
 Super Deluxe Series*

Patented Self-Cleaning Condenser

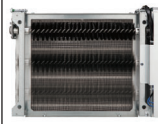

This product is equipped with a fine mesh filter to the front of the condenser to catch dust, and a rotating brush that moves up and down daily to remove excess buildup outward and away.

Model : TUF-28SD-D2-N



≡ FEATURES & BENEFITS ≡

- **Self-Cleaning Condenser**
 The accumulation of dust in the condenser can cause the failure or breakdown of refrigerators. Refrigerators run normally until they reach a certain level of accumulation. At some point, when they are over the limit, their performance drops quickly resulting in damage to, or disposal of the stored products inside. The Self-Cleaning Condenser device keeps the condenser clean and prevents system failure by automatically brushing daily.
- **Digital temperature control & monitor system**
 Keeps food products safe by maintaining constant temperatures. External digital display allows for easy monitoring.
- **Hydrocarbon refrigerants (R-290)**
 With innovative and eco-friendly technology, Turbo Air brings you hydrocarbon refrigerators designed to meet DOE's Energy Conservation Standards in 2017 and to use EPA's SNAP Program approved HC refrigerants. Hydrocarbon refrigerants do not deplete the ozone layer and have very low contribution to global warming (ODP-0, GWP-3).
- **High-density polyurethane insulation**
 The entire cabinet structure and solid doors are foamed-in-place using high density, CFC free polyurethane insulation.
- **Stainless steel cabinet construction**
 The Turbo Air Super Deluxe model boasts a stainless steel interior and exterior (galvanized steel back & bottom). It guarantees the utmost in cleanliness and long product life. The Super Deluxe adds a touch of style to the most refined setting.
- **Ergonomically designed doors**
 Customers' fatigue fades away with easy grip handles and doors that open effortlessly. These features along with self-closing doors make this the ultimate choice in customer convenience. ABS sheet door liners resist water condensation with thermal efficiency.
- **Each drawer accommodates up to 6" deep, one (1) full size pan or three (3) 1/3 size pans or six (6) 1/6 size pans (drawer pans not included)**
- **Freezer holds -10°F ~ 0°F for the best in frozen food preservation**



| Model | Swing Doors | Drawers | CU./FT. | #of Shelves | HP | AMPS | Crated Weight (lbs.) | L x D x H [†] (inches) |
|---------------|-------------|---------|---------|-------------|-----|------|----------------------|---------------------------------|
| TUF-28SD-D2-N | - | 2 | 6.8 | - | 2/5 | 2.6 | 169 | 27 1/2 x 30 x 30 |

Model : TUF-28SD-D2-N

| ELECTRICAL DATA | |
|----------------------------|--|
| Voltage | 115/60/1 |
| Plug Type |  NEMA 5-15P |
| Full Load Amperes | 2.6 |
| Compressor HP | 2/5 |
| Cord Length (ft.) | 9 |
| Refrigerant | R-290 |
| DIMENSIONAL DATA | |
| Net Capacity (cu. ft.) | 6.8 |
| Ext. Length Overall (in.) | 27 1/2 (698mm) |
| Ext. Depth Overall (in.)* | 30 (762mm) |
| Ext. Height Overall (in.)† | 30 (762mm) |
| # of Doors | - |
| # of Drawers | 2 |
| # of Shelves | - |
| Net Weight (lbs.) | 152 |
| Gross Weight (lbs.) | 169 |

Design and specifications subject to change without notice.

Actual shipping weight may differ due to extra packing materials for product protection.

* Depth does not include 1" for rear spacers.

† Height does not include 5-5/8" for caster height.

■ **WARRANTY : 5 Year Parts and Labor Warranty
7 Year Compressor Warranty**

■ **STANDARD FEATURES**

- *Anti-corrosion coated evaporator*
- *Self-contained system*
- *4" dia. swivel casters with locks on the front set*

■ **OPTIONAL ACCESSORIES**

- 1" caster, 1/2" diameter & 13 TPI: S28R813660 (non-brake)
- 2.5" caster, 1/2" diameter & 13 TPI: 30265H0100 (non-brake), 30265H0200 (w/ brake)
- 5" caster, 1/2" diameter & 13 TPI: M726500100 (non-brake), M726500200 (w/ brake)
- Leveling leg, 1/2" - 13 TPI x 1.54": LFM1213566
- 6" ABS plastic leg: 30221M0200
- 6" stainless steel leg: 30221M0600
- Back splash guard: TU-28B

PLAN VIEW

(unit : inch)

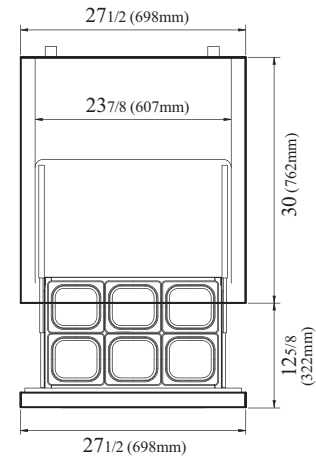

TOP VIEW

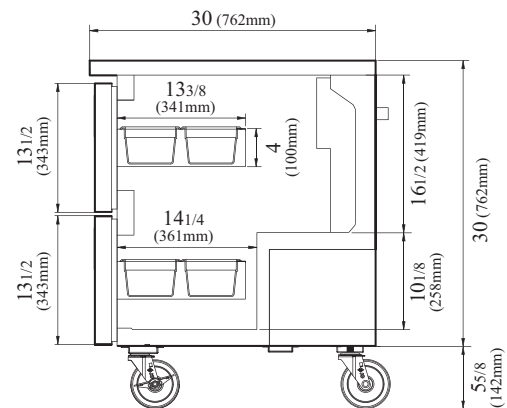

SIDE VIEW

Ver.20230113



- Turbo Air : 800-627-0032 ■ GK : 800-500-3519
■ Warranty : 800-381-7770 ■ AC : 888-900-1002