

REFRIGERATOR MANUFACTURER
Turbo air
 more durable, efficient, beautiful

4184 E. Conant St.
 Long Beach, CA 90808
 Tel. 310-900-1000
 Fax. 310-900-1077
www.turboairinc.com

Project:	
Model #:	
Item #:	
Available W/H:	Qty:
Approval:	
AIA #:	SIS #:
CSI Section 11400	

Undercounter Freezer

*Undercounters
 Super Deluxe Series*

Patented Self-Cleaning Condenser



This product is equipped with a fine mesh filter to the front of the condenser to catch dust, and a rotating brush that moves up and down daily to remove excess buildup outward and away.

Model : TUF-60SD-N



≡ FEATURES & BENEFITS ≡

- Self-Cleaning Condenser**
 The accumulation of dust in the condenser can cause the failure or breakdown of refrigerators. Refrigerators run normally until they reach a certain level of accumulation. At some point, when they are over the limit, their performance drops quickly resulting in damage to, or disposal of the stored products inside. The Self-Cleaning Condenser device keeps the condenser clean and prevents system failure by automatically brushing daily.
- Digital temperature control & monitor system**
 Keep food products safe by maintaining constant temperatures. External digital display allows for easy monitoring.
- Hydrocarbon refrigerants (R-290)**
 With innovative and eco-friendly technology, Turbo Air brings you hydrocarbon refrigerators designed to meet DOE's Energy Conservation Standards in 2017 and to use EPA's SNAP Program approved HC refrigerants. Hydrocarbon refrigerants do not deplete the ozone layer and have very low contribution to global warming (ODP-0, GWP-3).
- High-density polyurethane insulation**
 The entire cabinet structure and solid doors are foamed-in-place using high density, CFC free polyurethane insulation.
- Magnetic door gaskets**
 Magnetic door gaskets are of one-piece construction, removable without tools for ease of cleaning and replacement.
- Stainless steel cabinet construction**
 The Turbo Air Super Deluxe model boasts a stainless steel interior and exterior (galvanized steel back & bottom). It guarantees the utmost in cleanliness and long product life. The Super Deluxe adds a touch of style to the most refined setting.
- LED interior lighting & fan control**
 Energy efficient LED lighting lights every corner, making items easy to find. Fan control function automatically shuts off the fan when the door is open, which prevents hot air from being drawn in, thus maintaining the cool inner temperature.
- Sturdy, clean stainless steel shelving**
 Shelves are the most important part of cleanliness as they come in direct contact with food. After a while, PVC coated wire shelves may peel, rust and lead to unsanitary conditions. Only the Turbo Air Super Deluxe series uniquely provides stainless steel shelving.
- Ergonomically designed doors**
 Customers' fatigue fades away with easy grip handles and doors that open effortlessly. These features along with self-closing doors make this the ultimate choice in customer convenience. ABS sheet door liners resist water condensation with thermal efficiency.
- Freezer holds -10°F ~ 0°F for the best in frozen food preservation**

NATURAL Refrigerant

ISO9001:2008

ETL Intertek

ETL Intertek

3 YEAR WARRANTY

Compressor 7 YEAR WARRANTY (U.S.A. only)

Model	Swing Doors	CU./FT.	#of Shelves	HP	AMPS	Crated Weight (lbs.)	L x D* x H† (inches)
TUF-60SD-N	2	17	2	1/2	4.2	282	60 1/4 x 30 x 30

Model : TUF-60SD-N

ELECTRICAL DATA	
Voltage	115/60/1
Plug Type	 NEMA 5-15P
Full Load Amperes	4.2
Compressor HP	1/2
Cord Length (ft.)	9
Refrigerant	R-290
DIMENSIONAL DATA	
Net Capacity (cu. ft.)	17
Ext. Length Overall (in.)	60 1/4 (1530mm)
Ext. Depth Overall (in.)*	30 (762mm)
Ext. Height Overall (in.)†	30 (762mm)
# of Doors	2
# of Shelves	2
Shelf Size (L x D) (in.)	27 x 17
Net Weight (lbs.)	243
Gross Weight (lbs.)	282

Design and specifications subject to change without notice.

Actual shipping weight may differ due to extra packing materials for product protection.

* Depth does not include 1" for rear spacers.

† Height does not include 5-5/8" for caster height.

■ **WARRANTY : 3 Year Parts and Labor Warranty**
Additional 4 Year Warranty on Compressor

■ **STANDARD FEATURES**

- *Anti-corrosion coated evaporator*
- *Self-contained system*
- *Standard 4" dia. swivel casters with locks on the front set*
- *Door locks standard*

■ **OPTIONAL ACCESSORIES**

- 1" caster, 1/2" diameter & 13 TPI: S28R813660 (non-brake)
- 2.5" caster, 1/2" diameter & 13 TPI: 30265H0100 (non-brake), 30265H0200 (w/ brake)
- 5" caster, 1/2" diameter & 13 TPI: M726500100 (non-brake), M726500200 (w/ brake)
- Leveling leg, 1/2" - 13 TPI x 1.54": LFM1213566
- 6" ABS plastic leg: 30221M0200
- 6" stainless steel leg: 30221M0600
- Back splash guard: TU-60B
- Single overshef, stainless steel, 60-3/8" W: TSOS-5S
- Double overshef, 18/304 stainless steel, 60-1/4" W: TSOS-5R

PLAN VIEW

(unit : inch)

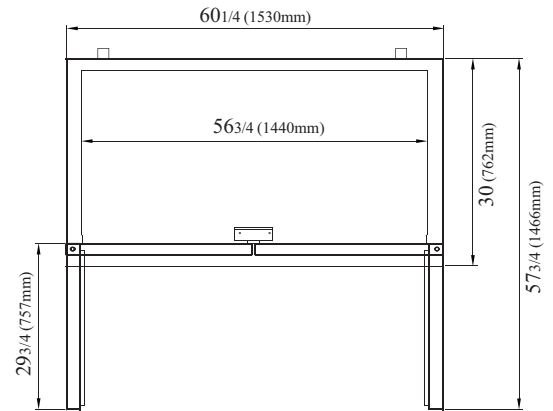

TOP VIEW

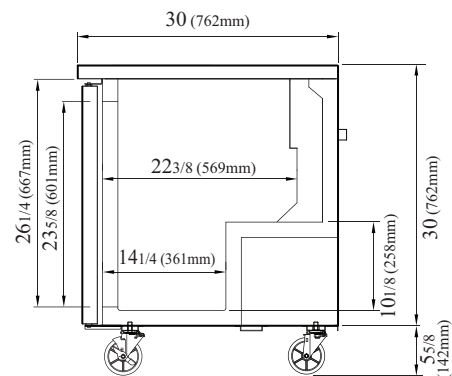

SIDE VIEW

Ver.20210722



- Turbo Air : 800-627-0032
- GK : 800-500-3519
- Warranty : 800-381-7770
- AC : 888-900-1002



Continued product development may necessitate specification changes without notice.