

REFRIGERATOR MANUFACTURER
Turbo air
 more durable, efficient, beautiful

4184 E. Conant St.
 Long Beach, CA 90808
 Tel. 310-900-1000
 Fax. 310-900-1077
www.turboairinc.com

Project :	
Model # :	
Item # :	Qty :
Available W/H :	
Approval :	

Ice Merchandiser

Ice Merchandisers
 Glass Door Merchandisers

FEATURES & BENEFITS

Model : TGIM-49W-N

Self-Cleaning Condenser

The accumulation of dust in the condenser can cause the failure or breakdown of refrigerators. Refrigerators run normally until they reach a certain level of accumulation. At some point, when they are over the limit, their performance drops quickly resulting in damage to, or disposal of the stored products inside. The Self-Cleaning Condenser device keeps the condenser clean and prevents system failure by automatically brushing daily.

Digital temperature control & monitor system

- Keep food products safe by maintaining constant temperatures.
- Alarms that sound when doors are not sealed shut; protect against food spoilage that originates from cold air leaks.
- Digital display allows for easy monitoring.
- Programs interpret the condition of refrigeration systems by self-diagnosis.
- Rapid cool-down function (Turbo Freeze).
- Smart defrost system will defrost as needed.
- Automatic evaporator fan motor delays.

Hydrocarbon refrigerants (R-290)

With innovative and eco-friendly technology, Turbo Air brings you hydrocarbon refrigerators designed to meet DOE's Energy Conservation Standards in 2017 and to use EPA's SNAP Program approved HC refrigerants. Hydrocarbon refrigerants do not deplete the ozone layer and have very low contribution to global warming (ODP-0, GWP-3).

Ice stays frozen even in hot climates

Turbo Air ice merchandisers are based on a freezer system that is adjusted to the ideal temperature range for bagged ice storage, whereas our competitors use refrigerator based systems. This system maintains an avg. temperature of 12°F or lower, which eliminates the problem of ice melting during hot weather conditions.

Triple pane heated glass doors

Equipped with unique triple-pane heated glass doors which enhance energy efficiency by preventing heat transfers and minimizing condensation. Lightweight door construction reduces door maintenance, bushing wear, and facilitates smooth door opening.

No electrical cabinet heater is needed

Electrical heaters in freezers operate 24/7 in order to prevent water flow to the cabinet surface. This causes unnecessary energy consumption, and sometimes is the reason behind overheating. Instead of frame heaters, Turbo Air freezers harness the heat produced by the compressor during its condensing stage, eliminating any unnecessary energy consumption as well as providing the most efficient freezer performance available.

High-density polyurethane insulation

The entire cabinet structure is foamed-in-place using high density, HCFC free polyurethane insulation.

LED advertising panel

LED lighting offers 5 times longer lasting life than fluorescents and conserves energy as well.



Patented Self-Cleaning Condenser



This product is equipped with a fine mesh filter to the front of the condenser to catch dust, and a rotating brush that moves up and down daily to remove excess buildup outward and away.

LED interior lighting

Bottom mount compressor units

Turbo Air's bottom mount compressor allows easier access for service and extra storage space above. In addition, the lower area provides a cooler and less greasy operating environment which results in reduced compressor running time.

Freezer holds 10°F ~ 15°F for the best in bagged ice storage

NATURAL
Refrigerant

SPEC
ISO 9001:2008

ETL
Intertek

ETL
Intertek

2 YEAR
WARRANTY

5 YEAR
WARRANTY
(on compressor)

Model	Swing Door	# of Rack Shelves	# of Bottom Shelves	CU./FT.	HP	AMPS	Crated Weight (lbs.)	L x D x H (inches)
TGIM-49W-N	2	4	2	39.88	3/4	6.7	665	54 3/8 x 29 3/4 x 78 1/4

Model : TGIM-49W-N

ELECTRICAL DATA	
Voltage	115/60/1
Plug Type	Ⓢ NEMA 5-20P
Full Load Amperes	6.7
Compressor HP	3/4
Cord Length (ft.)	7
Refrigerant	R-290
DIMENSIONAL DATA	
# of Doors	2
Net Capacity (cu. ft.)	39.88
Ext. Length Overall (in.)	54 ³ / ₈ (1382mm)
Ext. Depth Overall (in.)*	29 ³ / ₄ (756mm)
Ext. Height Overall (in.)	78 ¹ / ₄ (1987mm)
Int. Length Overall (in.)	50 ¹ / ₂ (1283mm)
Int. Depth Overall (in.)	24 ¹ / ₈ (614mm)
Int. Height Overall (in.)	60 ³ / ₈ (1535mm)
# of Rack Shelves	4
# of Bottom Shelves	2
Net Weight (lbs.)	505
Gross Weight (lbs.)	665

Design and specifications subject to change without notice.
Actual shipping weight may differ due to extra packing materials for product protection.
* Depth does not include 1-3/8" for glass door handles.

■ **WARRANTY : 2 Year Parts and Labor Warranty**
Additional 3 Year Warranty on Compressor

■ **STANDARD FEATURES**

- Anti-corrosion coated evaporator
- Magnetic door gaskets

■ **OPTIONAL ACCESSORIES**

- 4" caster, 1/2" diameter & 13 TPI: G8F6500101 (non-brake), G8F6500201 (w/ brake)
- Sign panel (blank): P0145A1300-B

PLAN VIEW

(unit : inch)

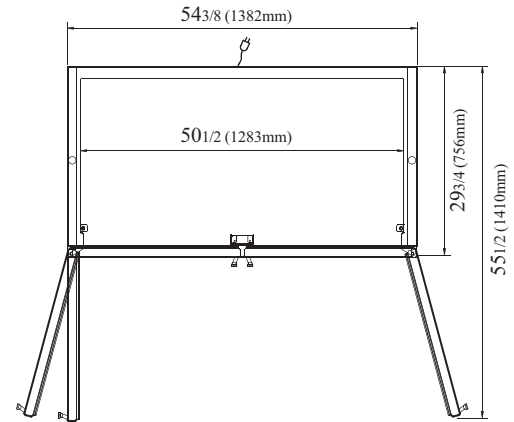

FRONT VIEW

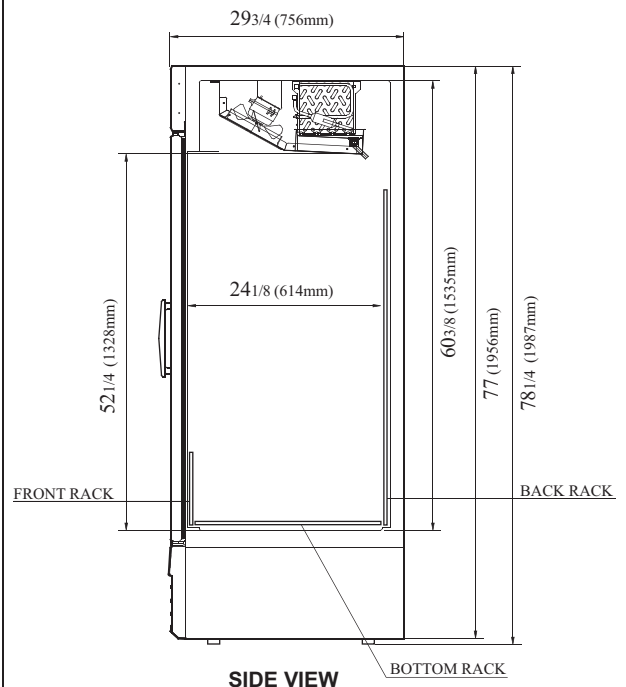

SIDE VIEW

Ver.20190926



- Turbo Air : 800-627-0032
- GK : 800-500-3519
- Warranty : 800-381-7770
- AC : 888-900-1002