

**REFRIGERATOR MANUFACTURER**  
**Turbo air**  
 more durable, efficient, beautiful

4184 E. Conant St.  
 Long Beach, CA 90808  
 Tel. 310-900-1000  
 Fax. 310-900-1077  
[www.turboairinc.com](http://www.turboairinc.com)

Project:	
Model #:	
Item #:	
Available W/H:	Qty:
Approval:	
AIA #:	SIS #:
CSI Section 11400	

## Mega Top Unit - Front Breathing Airflow

Food Prep Tables  
 Super Deluxe Series

### Patented Self-Cleaning Condenser

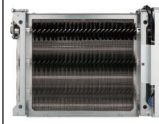

This product is equipped with a fine mesh filter to the front of the condenser to catch dust, and a rotating brush that moves up and down daily to remove excess buildup outward and away.

**Model : TST-60SD-24-FB-N**



### ≡ FEATURES & BENEFITS ≡

#### ■ Self-Cleaning Condenser

The accumulation of dust in the condenser can cause the failure or breakdown of refrigerators. Refrigerators run normally until they reach a certain level of accumulation. At some point, when they are over the limit, their performance drops quickly resulting in damage to, or disposal of the stored products inside. The Self-Cleaning Condenser device keeps the condenser clean and prevents system failure by automatically brushing daily.

#### ■ Digital temperature control & monitor system

Keeps food products safe by maintaining constant temperatures. External digital display allows for easy monitoring.

#### ■ Hydrocarbon refrigerants (R-290)

With innovative and eco-friendly technology, Turbo Air brings you hydrocarbon refrigerators designed to meet DOE's Energy Conservation Standards in 2017 and to use EPA's SNAP Program approved HC refrigerants. Hydrocarbon refrigerants do not deplete the ozone layer and have very low contribution to global warming (ODP-0, GWP-3).

#### ■ Cold Bunker system

Our innovative forced air system allows cold air to flow all around the food pan area, covering not only underneath the pan, but also the front, top and the rear. This unique air flow creates a cold air-shield around the pan, which maintains the food temperature at under 41°F (NSF requirement) even when the lids are opened. In addition, the compartment isolates pans from the reach-in area to prevent food spillage.

#### ■ Front Breathing airflow

Front Breathing airflow is designed to draw in air and discharge from the front, allowing units to run at high efficiency in tight spaces and eliminates the need for surrounding clearances.

#### ■ LED interior lighting & fan control

Energy efficient LED lighting lights every corner, making items easy to find. Fan control function automatically shuts off the fan when the door is open, which prevents hot air from being drawn in, thus maintaining the cool inner temperature.

#### ■ Stainless steel cabinet construction

The Turbo Air Super Deluxe model boasts a stainless steel interior (ABS door liner) and exterior (galvanized steel back & bottom). It guarantees the utmost in cleanliness and long product life. The Super Deluxe adds a touch of style to the most refined setting.

#### ■ Sturdy, clean stainless steel shelving

Shelves are the most important part of cleanliness as they come in direct contact with food. After a while, PVC coated wire shelves may peel, rust and lead to unsanitary conditions. Only the Turbo Air Super Deluxe series uniquely provides stainless steel shelving.

#### ■ Insulated pan cover

#### ■ High-density polyurethane insulation

The entire cabinet structure and solid doors are foamed-in-place high density, CFC free polyurethane insulation.

#### ■ 9-1/2" deep, 1/2" thick high-density Polyethylene cutting board included with convenient side rail

#### ■ Refrigerator holds 33°F ~ 39°F for the best in food preservation

NATURAL  
 Refrigerant

ETL  
 Intertek

ETL  
 Intertek

5 YEAR  
 WARRANTY

Compressor  
 7 YEAR  
 WARRANTY  
 U.S.A. only

Model	Swing Doors	CU./FT.	#of Shelves	#of Pans	HP	AMPS	Crated Weight (lbs.)	L x D x H <sup>†</sup> (inches)
TST-60SD-24-FB-N	2	17.6	2	24	1/3	4.4	352	60 1/4 x 34 x 39

## Model : TST-60SD-24-FB-N

ELECTRICAL DATA	
Voltage	115/60/1
Plug Type	 NEMA 5-15P
Full Load Amperes	4.4
Compressor HP	1/3
Cord Length (ft.)	9
Refrigerant	R-290
DIMENSIONAL DATA	
Ext. Length Overall (in.)	60 1/4 (1530mm)
Ext. Depth Overall (in.)*	34 (864mm)
Ext. Height Overall (in.)†	39 (991mm)
# of Doors	2
# of Shelves	2
# of Pans	24
# of Hood	2
Net Capacity (cu. ft.)	17.6
Shelf Size (L x D) (in.)	27 x 17
Net Weight (lbs.)	321
Gross Weight (lbs.)	352

Design and specifications subject to change without notice.  
Actual shipping weight may differ due to extra packing materials for product protection.  
\* Depth does not include 3" for cutting boards.  
† Height does not include 5-1/8" for caster height.

■ **WARRANTY : 5 Year Parts and Labor Warranty  
7 Year Compressor Warranty**

■ **STANDARD FEATURES**

- *Anti-corrosion coated evaporator*
- *Self-contained system*
- *4" dia. swivel casters with locks on the front set*
- *1/6 size, 4" deep condiment pans included*

■ **OPTIONAL ACCESSORIES**

- 1" caster, 1/2" diameter & 13 TPI: S28R813660 (non-brake)
- 2.5" caster, 1/2" diameter & 13 TPI: 30265H0100 (non-brake), 30265H0200 (w/ brake)
- 5" caster, 1/2" diameter & 13 TPI: M726500100 (non-brake), M726500200 (w/ brake)
- Leveling leg, 1/2" - 13 TPI x 1.54": LFM1213566
- 6" ABS plastic leg: 30221M0200
- 6" stainless steel leg: 30221M0600
- Additional stainless steel shelf: M607800100
- Removable food covers: RCT-60-24/72-30-R
- Single overshef, stainless steel, 60-3/8" W: TSOS-5S
- Double overshef, stainless steel, 60-3/8" W: TSOS-5R-T
- Clear lid: CL-60-24

## PLAN VIEW

(unit : inch)

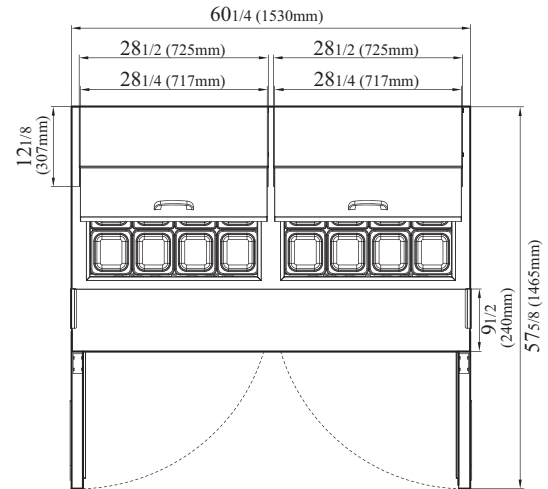

TOP VIEW

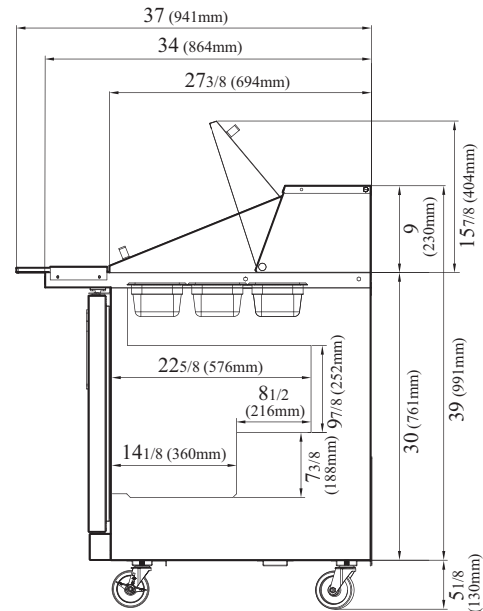

SIDE VIEW

Ver.20230815



- Turbo Air : 800-627-0032
- GK : 800-500-3519
- Warranty : 800-381-7770
- AC : 888-900-1002

