

REFRIGERATOR MANUFACTURER
Turbo air
 more durable, efficient, beautiful

4184 E. Conant St.
 Long Beach, CA 90808
 Tel. 310-900-1000
 Fax. 310-900-1077
www.turboairinc.com

Project:	
Model #:	
Item #:	
Available W/H:	Qty:
Approval:	
AIA #:	SIS #:
CSI Section 11400	

Undercounter Freezer - Front Breathing Airflow

Undercounters
 Super Deluxe Series

Patented Self-Cleaning Condenser



This product is equipped with a fine mesh filter to the front of the condenser to catch dust, and a rotating brush that moves up and down daily to remove excess buildup outward and away.

Model : TUF-28SD-FB-N



≡ FEATURES & BENEFITS ≡

- **Self-Cleaning Condenser**
 The accumulation of dust in the condenser can cause the failure or breakdown of refrigerators. Refrigerators run normally until they reach a certain level of accumulation. At some point, when they are over the limit, their performance drops quickly resulting in damage to, or disposal of the stored products inside. The Self-Cleaning Condenser device keeps the condenser clean and prevents system failure by automatically brushing daily.
- **Digital temperature control & monitor system**
 Keeps food products safe by maintaining constant temperatures. External digital display allows for easy monitoring.
- **Front Breathing airflow**
 Front Breathing airflow is designed to draw in air and discharge from the front, allowing units to run at high efficiency in tight spaces and eliminates the need for surrounding clearances.
- **Hydrocarbon refrigerants (R-290)**
 With innovative and eco-friendly technology, Turbo Air brings you hydrocarbon refrigerators designed to meet DOE's Energy Conservation Standards in 2017 and to use EPA's SNAP Program approved HC refrigerants. Hydrocarbon refrigerants do not deplete the ozone layer and have very low contribution to global warming (ODP-0, GWP-3).
- **High-density polyurethane insulation**
 The entire cabinet structure and solid doors are foamed-in-place using high density, CFC free polyurethane insulation.
- **LED interior lighting & fan control**
 Energy efficient LED lighting lights every corner, making items easy to find. Fan control function automatically shuts off the fan when the door is open, which prevents hot air from being drawn in, thus maintaining the cool inner temperature.
- **Stainless steel cabinet construction**
 The Turbo Air Super Deluxe model boasts a stainless steel interior and exterior (galvanized steel back & bottom). It guarantees the utmost in cleanliness and long product life. The Super Deluxe adds a touch of style to the most refined setting.
- **Sturdy, clean stainless steel shelving**
 Shelves are the most important part of cleanliness as they come in direct contact with food. After a while, PVC coated wire shelves may peel, rust and lead to unsanitary conditions. Only the Turbo Air Super Deluxe series uniquely provides stainless steel shelving.
- **Ergonomically designed doors**
 Customers' fatigue fades away with easy grip handles and doors that open effortlessly. These features along with self-closing doors make this the ultimate choice in customer convenience. ABS sheet door liners resist water condensation with thermal efficiency.
- **Freezer holds -10°F ~ 0°F for the best in frozen food preservation**



Model	Swing Doors	CU./FT.	#of Shelves	HP	AMPS	Crated Weight (lbs.)	L x D x H† (inches)
TUF-28SD-FB-N	1	11.1	1	1/4	4.5	195	27 1/2 x 30 x 30

Model : TUF-28SD-FB-N

ELECTRICAL DATA	
Voltage	115/60/1
Plug Type	 NEMA 5-15P
Full Load Amperes	4.5
Compressor HP	1/4
Cord Length (ft.)	10
Refrigerant	R-290
DIMENSIONAL DATA	
Net Capacity (cu. ft.)	11.1
Ext. Length Overall (in.)	27 1/2 (700mm)
Ext. Depth Overall (in.)	30 (762mm)
Ext. Height Overall (in.)†	30 (761mm)
# of Doors	1
# of Shelves	1
Shelf Size (L x D) (in.)	22 1/2 x 17
Net Weight (lbs.)	170
Gross Weight (lbs.)	195

Design and specifications subject to change without notice.
Actual shipping weight may differ due to extra packing materials for product protection.
† Height does not include 5-1/8" for caster height.

- **WARRANTY** : 5 Year Parts and Labor Warranty
7 Year Compressor Warranty

STANDARD FEATURES

- Anti-corrosion coated evaporator
- Self-contained system
- 4" dia. swivel casters with locks on the front set
- Door lock

OPTIONAL ACCESSORIES

- 5" caster, 1/2" diameter & 13 TPI: M726500100 (non-brake), M726500200 (w/ brake)
- Leveling leg, 1/2" - 13 TPI x 1.54": LFM1213566
- 6" ABS plastic leg: 30221M0200
- 6" stainless steel leg: 30221M0600
- Back splash guard: TU-28B

PLAN VIEW

(unit : inch)

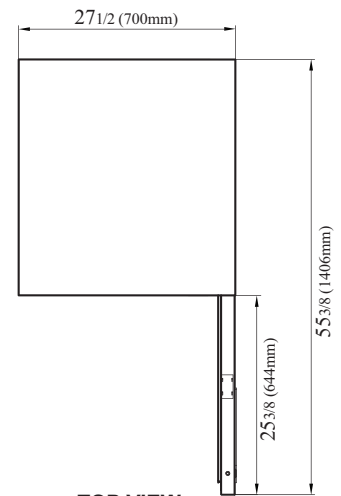

TOP VIEW

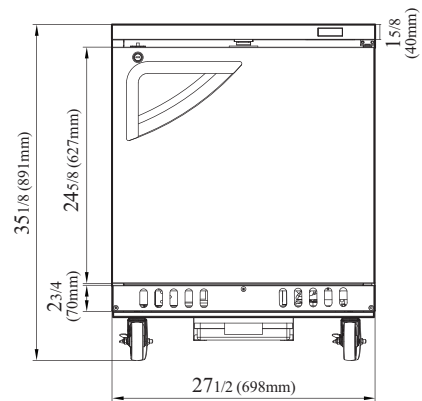

FRONT VIEW

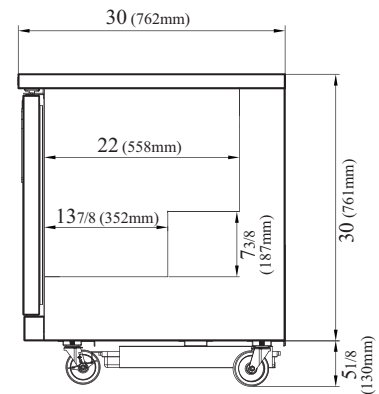

SIDE VIEW

Ver.20230719



- Turbo Air : 800-627-0032
- GK : 800-500-3519
- Warranty : 800-381-7770
- AC : 888-900-1002