

REFRIGERATOR MANUFACTURER
Turbo air
 more durable, efficient, beautiful

4184 E. Conant St.
 Long Beach, CA 90808
 Tel. 310-900-1000
 Fax. 310-900-1077
www.turboairinc.com

Project:	
Model #:	
Item #:	
Available W/H:	Qty:
Approval:	
AIA #:	SIS #:
CSI Section 11400	

Chef Base Freezer - Flat Top

*Chef Bases
 PRO Series*

Patented Self-Cleaning Condenser



This product is equipped with a fine mesh filter to the front of the condenser to catch dust, and a rotating brush that moves up and down daily to remove excess buildup outward and away.

Model : PRCBE-60F-N-FT

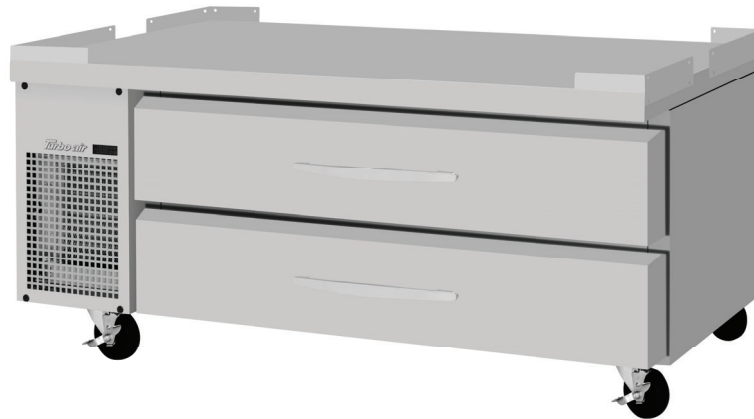

≡ FEATURES & BENEFITS ≡

■ Self-Cleaning Condenser

The accumulation of dust in the condenser can cause the failure or breakdown of refrigerators. Refrigerators run normally until they reach a certain level of accumulation. At some point, when they are over the limit, their performance drops quickly resulting in damage to, or disposal of the stored products inside. The Self-Cleaning Condenser device keeps the condenser clean and prevents system failure by automatically brushing daily.

■ Hydrocarbon refrigerants (R-290)

With innovative and eco-friendly technology, Turbo Air brings you hydrocarbon refrigerators designed to meet DOE's Energy Conservation Standards in 2017 and to use EPA's SNAP Program approved HC refrigerants. Hydrocarbon refrigerants do not deplete the ozone layer and have very low contribution to global warming (ODP-0, GWP-3).

■ Digital temperature display on front panel

■ Strong body and durable construction

Built with heavy duty 16 ga. stainless steel, Chef Base top is manufactured of one-piece reinforced stainless steel to ensure durability.

■ Countertops

PRCBE-36/48/60F-N-FT supports up to 788 pounds of equipment.
 PRCBE-72/84/96F-N-FT supports up to 1,192 pounds of equipment.

■ Each drawer accommodates up to 6" deep three (3) full size pans

■ Top is insulated to eliminate heat transfer to the interior of cabinet

■ Side mount compressor unit

Compressors positioned on the side of the units makes servicing our units easy. Our front air intake feature also allows this model to be highly efficient in narrow spaces.

■ High-density polyurethane insulation

The entire cabinet structure and solid doors are foamed-in-place using high density, CFC free polyurethane insulation.

■ Durable stainless steel drawers

■ Stainless steel flat top

■ Hot gas condensate system

■ Full length drawer with gasket guard

■ Drawer slider load capacity up to 180 lbs

■ Magnetic snap-in gasket

■ Freezer holds -10°F ~ 0°F for the best in frozen food preservation



Model	Drawers	CU./FT.	HP	AMPS	Crated Weight (lbs.)	L x D* x H† (inches)
PRCBE-60F-N-FT	2	9.77	3/8	6.4	377	60 1/8 x 33 1/2 x 21 3/8

Model : PRCBE-60F-N-FT

ELECTRICAL DATA		
Voltage	115/60/1	
Plug Type	 NEMA 5-15P	
Full Load Amperes	6.4	
Compressor HP	3/8	
Cord Length (ft.)	9	
Refrigerant	R-290	
DIMENSIONAL DATA		
Ext. Length Overall (in.)	60 1/8 (1528mm)	
Ext. Depth Overall (in.)*	33 1/2 (852mm)	
Ext. Height Overall (in.)†	21 3/8 (544mm)	
# of Drawers	2	
# of Pans	Top	(1) 1/3 size, (16) 1/6 size
	Bottom	(18) 1/6 size
Net Capacity (cu. ft.)	9.77	
Net Weight (lbs.)	322	
Gross Weight (lbs.)	377	

Design and specifications subject to change without notice.

Actual shipping weight may differ due to extra packing materials for product protection.

* Depth does not include 1/2" for drawer handles. † Height does not include 4-1/2" for caster height.

■ WARRANTY : 5 Year Parts and Labor Warranty 7 Year Compressor Warranty

■ STANDARD FEATURES

- Anti-corrosion coated evaporator
- Self-contained system
- 4" dia. swivel casters

■ OPTIONAL ACCESSORIES

- 5" caster, 1/2" diameter & 13 TPI: M726500100 (non-brake), M726500200 (w/ brake)
- Leveling leg, 1/2" - 13 TPI x 1.54": LFM1213566
- 6" ABS plastic leg: 30221M0200
- 6" stainless steel leg: 30221M0600

PLAN VIEW

(unit : inch)

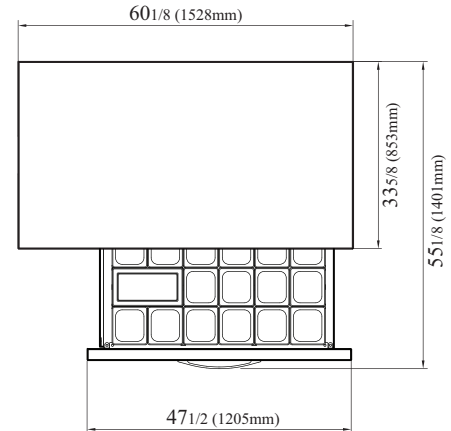

TOP VIEW

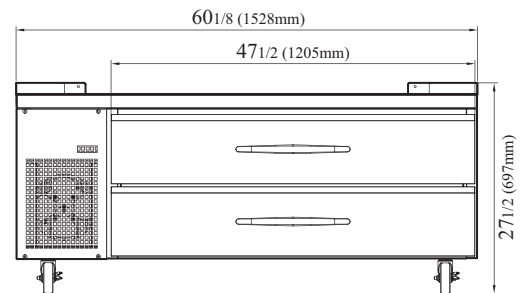

FRONT VIEW

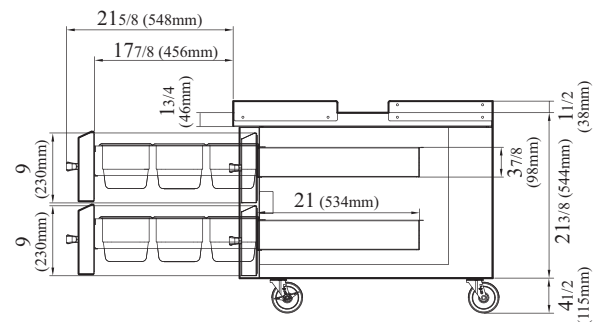

SIDE VIEW

Ver.20240501



- Turbo Air: 800-627-0032
- Radiance: 800-500-3519
- Warranty: 800-381-7770
- AC: 888-900-1002