

**REFRIGERATOR MANUFACTURER**  
**Turbo air**  
 more durable, efficient, beautiful

4184 E. Conant St.  
 Long Beach, CA 90808  
 Tel. 310-900-1000  
 Fax. 310-900-1077  
[www.turboairinc.com](http://www.turboairinc.com)

Project:	
Model #:	
Item #:	
Available W/H:	Qty:
Approval:	
AIA #:	SIS #:
CSI Section 11400	

## Worktop Refrigerator - Front Breathing Airflow / Drawers Worktops PRO Series

### Patented Self-Cleaning Condenser

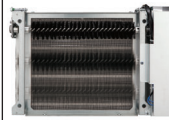

This product is equipped with a fine mesh filter to the front of the condenser to catch dust, and a rotating brush that moves up and down daily to remove excess buildup outward and away.

**Model : PWR-48-D2R(L)-FB-N**



**PWR-48-D2L-FB-N**



**PWR-48-D2R-FB-N**

### ≡ FEATURES & BENEFITS ≡

- Self-Cleaning Condenser**  
 The accumulation of dust in the condenser can cause the failure or breakdown of refrigerators. Refrigerators run normally until they reach a certain level of accumulation. At some point, when they are over the limit, their performance drops quickly resulting in damage to, or disposal of the stored products inside. The Self-Cleaning Condenser device keeps the condenser clean and prevents system failure by automatically brushing daily.
- Digital temperature control & monitor system**  
 Keeps food products safe by maintaining constant temperatures. External digital display allows for easy monitoring.
- Front Breathing airflow**  
 Front Breathing airflow is designed to draw in air and discharge from the front, allowing units to run at high efficiency in tight spaces and eliminates the need for surrounding clearances.
- Hydrocarbon refrigerants (R-290)**  
 With innovative and eco-friendly technology, Turbo Air brings you hydrocarbon refrigerators designed to meet DOE's Energy Conservation Standards in 2017 and to use EPA's SNAP Program approved HC refrigerants. Hydrocarbon refrigerants do not deplete the ozone layer and have very low contribution to global warming (ODP-0, GWP-3).
- Stainless steel cabinet construction**  
 The PRO series model boasts a stainless steel interior (Aluminum door liner) and a **22 gauge** stainless steel exterior (galvanized steel bottom). It guarantees the utmost in cleanliness and long product life. The PRO series adds a touch of style to the most refined setting.
- LED interior lighting & fan control**  
 Energy efficient LED lighting lights every corner, making items easy to find. Fan control function automatically shuts off the fan when the door is open, which prevents hot air from being drawn in, thus maintaining the cool inner temperature.
- High-density polyurethane insulation**  
 The entire cabinet structure and solid doors are foamed-in-place using high density, CFC free polyurethane insulation.
- Each top drawer accommodates up to 6" deep, one (1) full size pan or two (2) 1/3 size pans with two (2) 1/6 size pans or six (6) 1/6 size pans. And each bottom drawer accommodates up to 6" deep, two (2) 1/3 size pans or four (4) 1/6 size pans (drawer pans not included)**
- Refrigerator holds 33°F ~ 39°F for the best in food preservation**
- Lifetime guaranteed heavy duty hinges and handles**
- Built to maintain NSF standard temperatures in 100°F ambient**
  - PWR-48-D2R-FB-N: (Left)Drawers + (Right)Right hinged door
  - PWR-48-D2L-FB-N: (Right)Drawers + (Left)Left hinged door

**NATURAL Refrigerant**



MADE IN U.S.A.



Model	Swing Doors	Drawers	CU./FT.	#of Shelves	HP	AMPS	Crated Weight (lbs.)	L x D x H <sup>†</sup> (inches)
<b>PWR-48-D2R(L)-FB-N</b>	<b>1</b>	<b>2</b>	<b>9.8</b>	<b>1</b>	<b>1/6</b>	<b>6.5</b>	<b>285</b>	<b>48 1/4 x 30 x 34 1/8</b>

## Model : PWR-48-D2R(L)-FB-N

ELECTRICAL DATA	
Voltage	115/60/1
Plug Type	 NEMA 5-15P
Full Load Amperes	6.5
Compressor HP	1/6
Cord Length (ft.)	9
Refrigerant	R-290
DIMENSIONAL DATA	
Net Capacity (cu. ft.)	9.8
Ext. Length Overall (in.)	48 1/4 (1225mm)
Ext. Depth Overall (in.)*	30 (762mm)
Ext. Height Overall (in.)†	34 1/8 (868mm)
# of Door	1
# of Drawer	2
# of Shelves	1
Shelf Size (L x D) (in.)	21 x 17
Net Weight (lbs.)	238
Gross Weight (lbs.)	285

Design and specifications subject to change without notice.

Actual shipping weight may differ due to extra packing materials for product protection.

\* Depth does not include 7/8" for door handle.

† Height does not include 4-1/2" for caster height.

- **WARRANTY :** 5 Year Parts and Labor Warranty  
7 Year Compressor Warranty

### STANDARD FEATURES

- Anti-corrosion coated evaporator
- Self-contained system
- 4" dia. swivel casters with locks on the front set
- Door locks

### OPTIONAL ACCESSORIES

- 1" caster, 1/2" diameter & 13 TPI: S28R813660 (non-brake)
- 2.5" caster, 1/2" diameter & 13 TPI: 30265H0100 (non-brake), 30265H0200 (w/ brake)
- 5" caster, 1/2" diameter & 13 TPI: M726500100 (non-brake), M726500200 (w/ brake)
- Leveling leg, 1/2" - 13 TPI x 1.54": LFM1213566
- 6" ABS plastic leg: 30221M0200
- 6" stainless steel leg: 30221M0600
- Single overshef, stainless steel, 48-3/8" W: TSOS-4SW

Ver.20240812

## PLAN VIEW

(unit : inch)

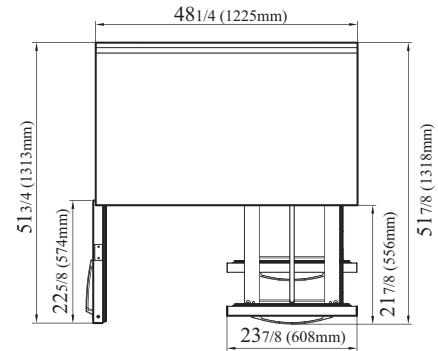

PWR-48-D2L-FB-N  
TOP VIEW

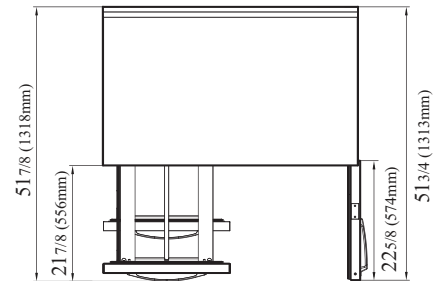

PWR-48-D2R-FB-N  
TOP VIEW

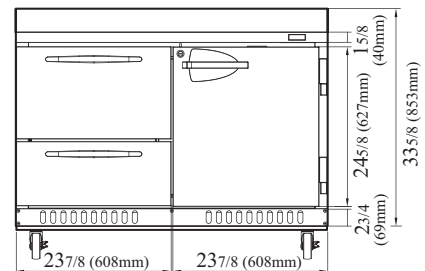

PWR-48-D2R-FB-N  
FRONT VIEW

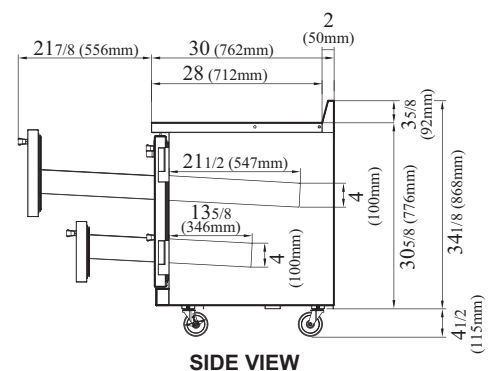

SIDE VIEW



- Turbo Air: 800-627-0032
- Radiance: 800-500-3519
- Warranty: 800-381-7770
- AC: 888-900-1002